

Lobestar® Shear/Mixer

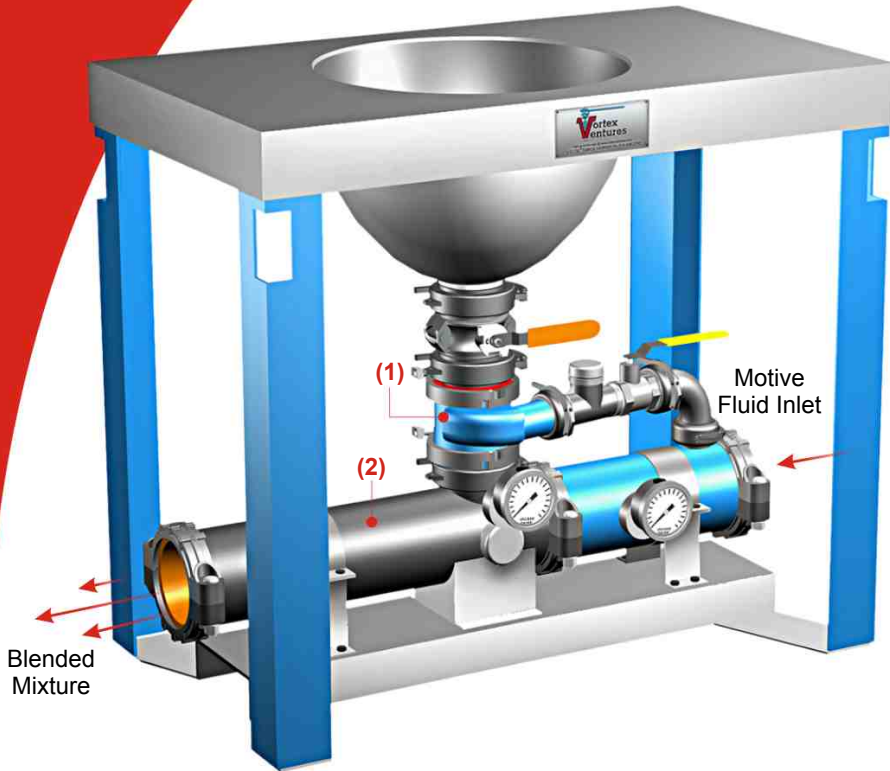

Fig.1 Lobestar® Shear/Mixer Model V VE-U-6S

The introduction of new drilling fluids has presented a challenge in adequate mixing and delivery techniques. The **LOBESTAR® SHEAR/MIXER** meets the demanding requirements for getting the most potential from a chemical product.

The **LOBESTAR® SHEAR/MIXER** is a combination of two major components that are essential in providing rapid hydration, uniform dispersion and fast delivery. The two components that make-up the **LOBESTAR® SHEAR/MIXER** are the:

- (1) **Radial Premixer**
- (2) **Lobestar® Mixing Eductor**

Benefits:

- * Speed Mixing
- * Dynamic Shearing
- * Rapid Hydration
- * Uniform Blend
- * Max Performance
- * Stabilization
- * Dust Containment
- * Long Distance Delivery
- * Minimum Air Induction
- * No Moving Parts

Radial Premixer

A slip stream is diverted from the primary pressurized flow to a tangential inlet to the **RADIAL PREMIXER** that is positioned above the **LOBESTAR® MIXING EDUCTOR** suction inlet. The partial flow stream entering produces a strong vortex and radiates outwardly to the wall of the **RADIAL PREMIXER**. Powdered and granular materials that are led through the parabolic hopper located above the **PREMIXER** are drawn into a low pressure eye of the swirling fluid. The centrifugal force that is generated in the **RADIAL PREMIXER** separates the individual particles as the "wetting-out" process is completed. This eliminates clumping, "fish-eyes" and microgels. The slurry is then drawn into the mixing chamber of the **MIXING EDUCTOR**.

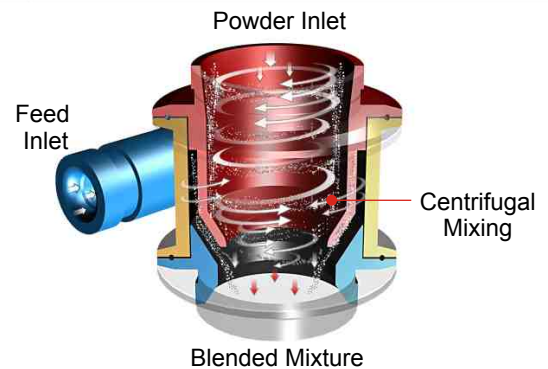

Lobestar® Mixing Eductor

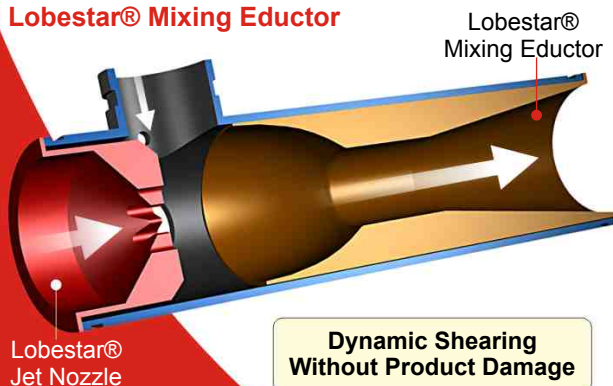

The **LOBESTAR® MIXING EDUCTOR** utilizes a continuous pressurized liquid stream as the motive powder, generally a centrifugal pump, to convert the pressure energy into a high velocity stream. The high velocity liquid stream, caused by the converging geometry of the **LOBESTAR® JET NOZZLE** produces a low pressure region (near-perfect vacuum @ 25 PSI) in the mixing chamber of the **EDUCTOR**, drawing in the premixed slurry from the **RADIAL PREMIXER**. The **LOBESTAR® JET NOZZLE** orifice configuration generates both axial and radial vortices that interact and cause enhanced interfacial contact in the mixing chamber of the **LOBESTAR® MIXING EDUCTOR**. This downstream interaction provides turbulent mixing and dynamic shear. The results are rapid hydration, uniform dispersion and fast delivery.

Lobestar® Shear/Mixer



**Lobestar® Shear/Mixer
Model V VE-U-6S**

Spin-cast Stainless Steel
Hopper

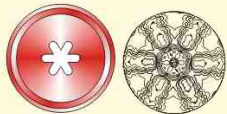

Lobestar® Jet Nozzle
and pressure profile of
distribution at 60 PSI.

Features:

- * No Moving Parts
- * High Abrasion Durability
- * Chemical Compatibility
- * Non- Corrosive Parts
- * Quick-Disconnects

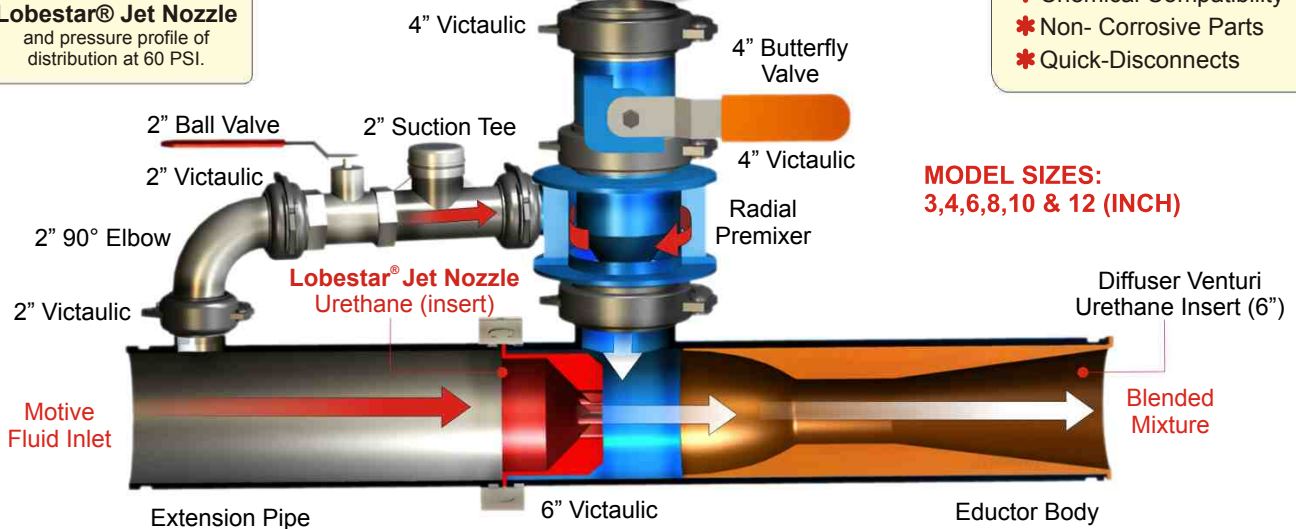

**MODEL SIZES:
3,4,6,8,10 & 12 (INCH)**

"The ability of a fluid to perform a specific function is dependent on its rheological properties. Adequate mixing, entrainment and shearing are essential in providing product performance."

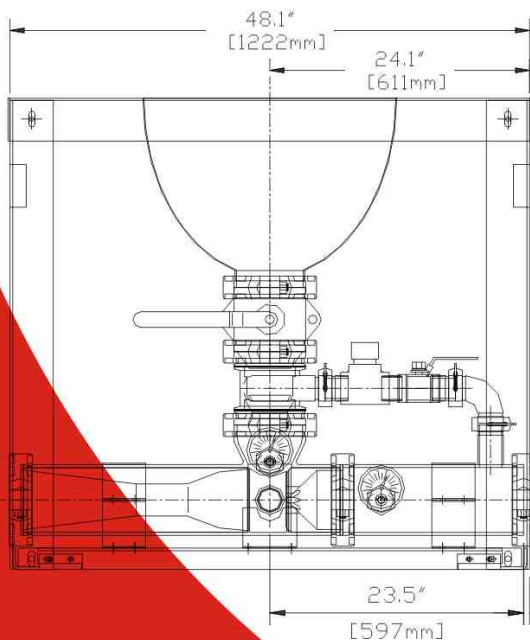

**Custom
Solutions to Fit
Your Needs**

**Net wt: 585 lbs.
(265kg)**

